

PERMIT

CITY OF NAPOLEON - BUILDING DEPARTMENT

255 West Riverview Avenue, Napoleon, Ohio 43545 - 419-592-4010

Permit No. 01139 Issued 2-26-86
date

Job Location 70 Joliette Drive
address

Lot 74 Riviera Heights 3rd. Add'n.
sub-div or legal discript

Issued By Ron Sonnenberg
building official

Owner Ron Zachrich 762-5277
name tel.

Address Route 2 Napoleon, Ohio 43545

Agent Ron Zachrich Bldr. 762-5277
builder-eng.-etc. tel.

Address Rt. 2 Napoleon, Ohio 43545

Description of Use Residential

Residential one
no. dwelling units

Commercial _____ Industrial _____

New XX Add'n. _____ Alter _____ Remodel _____

Mixed Occupancy n/a

Change of Occupancy n/a

Estimated Cost \$ 52,000.00

FEES	BASE	PLUS	TOTAL
<input checked="" type="checkbox"/> BUILDING	\$87.00	-0-	\$ 87.00
<input checked="" type="checkbox"/> ELECTRICAL	5.00	\$18.00	23.00
<input checked="" type="checkbox"/> PLUMBING	3.00	10.00	13.00
<input checked="" type="checkbox"/> MECHANICAL	6.00	-0-	6.00
<input type="checkbox"/> DEMOLITION			
<input checked="" type="checkbox"/> ZONING	-0-	-0-	-0-
<input type="checkbox"/> SIGN			
WATER TAP	300.00	-0-	300.00
SEWER TAP	60.00	-0-	60.00
TEMP. ELECT.	10.00	-0-	10.00
ADDITIONAL PLAN REVIEW	Struct. _____ hrs _____ Elect. _____ hrs _____		
TOTAL FEES.....			\$499.00
LESS MIN. FEES PAID _____ <small>date</small>			-0-
BALANCE DUE.....			\$499.00

ZONING INFORMATION

district A	lot dimensions 78.99' x 125'	area 9873 sq. ft.	front yd 25'	side yds 7' min.	rear yd 15' min
max hgt 35'	no pkg spaces two	no ldg spaces n/a	max cover 35%	petition or appeal req'd no	date appr n/a

WORK INFORMATION:

Size: Length 64' Width 34'4" Stories 1 Ground Floor Area 1824 sq. ft.

Height 1 story Building Volume (for demo. permit) _____ cu. ft.

Electrical: New 200 A. Service and 18 circuits.
brief description

Plumbing: Water & san. Sewer service & interior plumbing.
brief description

Mechanical: 110,000 BTU warm air furnace.
brief description

Sign: n/a Dimensions _____ Sign Area MAR 10 1986
type

Additional Information: See attached Addendum.

PAID

CITY OF NAPOLEON

Date 3-10-86 Applicant Signature Ron Zachrich
owner-agent

INSPECTION RECORD

	UNDERGROUND			ROUGH-IN						FINAL		
	Type	Date	By	Type	Date	By	Type	Date	By	Type	Date	By
PLUMBING	Building Drains	4/86	REL	Drainage, Waste & Vent Piping	4/86	REL	Indirect Waste			Drainage, Waste & Vent Piping	6/24/86	REL
	Water Piping									Backflow Prevention		
	Building Sewer	4/86	REL	Water Piping	"	"	Condensate Lines			Water Heater		
	Sewer Connection	"	REL							FINAL APPROVAL	6/24/86	REL
MECHANICAL	Refrigerant Piping			Refrigerant Piping			Chimney(s)			Grease Exhaust System	6/24/86	REL
				Duct Furnace(s)			Fire Dampers			Air Cond. Unit(s)		
	Ducts/Plenums			Ducts/Plenums	4/23/86	REL	<input type="checkbox"/> Radiant Htr(s) <input type="checkbox"/> Unit Htr(s)			Refrigeration Equipment		
				Duct Insulation	Ground Insulated	REL	Pool Heater			Furnace(s)	6/24/86	REL
				Combustion Products Vents	6/23/86	REL	Ventilation <input type="checkbox"/> Supply <input type="checkbox"/> Exhst.			FINAL APPROVAL	6/24/86	REL
ELECTRICAL	Conduits & or Cable			Conduits/Cable			<input type="checkbox"/> Range <input type="checkbox"/> Dryer			Temp Service Temp Lighting		
	Grounding & or Bonding			Rough Wiring			<input type="checkbox"/> Generator(s) <input type="checkbox"/> Motors			Fixtures Lampholders		
	Floor Ducts Raceways			Service Panel Switchboard			<input type="checkbox"/> Water Htr <input type="checkbox"/> Welder			Signs		
	Service Conduit			Busways Ducts			<input type="checkbox"/> Heaters <input type="checkbox"/> Heat Cable			Electric Mtr. Clearance		
	Temporary Power Pole			Subpanels			<input type="checkbox"/> Duct Htr(s) <input type="checkbox"/> Furnace(s)			FINAL APPROVAL		
BUILDING	Location, Set-backs, Esmt(s)	2/24/86	REL	Exterior Wall Construction	4/86	REL	Roof Covering Roof Drainage	4/86	REL	Smoke Detector	6/23/86	REL
	Excavation	"	REL				Exterior Lath			Demolition (sewer cap)		
	Footings & Reinforcing	"	REL				<input type="checkbox"/> Interior Lath <input checked="" type="checkbox"/> Wallboard	3/86	REL			
	Floor Slab	4/86	REL	Interior Wall Construction	"	REL	Fire Wall(s)	4/23/86	REL	Building or Structure	6/23/86	REL
	Foundation Walls	3/5/86	REL	Columns & Supports			Fireplace Chimney	5/86	REL			
	Sub-soil Drain			Crawl Space <input checked="" type="checkbox"/> Vent <input checked="" type="checkbox"/> Access	3/5/86	REL	Attic <input checked="" type="checkbox"/> Vent <input checked="" type="checkbox"/> Access	"	REL			
	Piles			Floor System(s)	4/86	REL				FINAL APPROVAL BLDG. DEPT.		REL
				Roof System	"	REL	Special Insp Reports Rec'd			Certificate of Occupancy Issued	# 428 6-23-86	REL
ADDITIONAL	INSPECTIONS, CORRECTIONS, ETC.						INSPECTIONS, CORRECTIONS, ETC.					
	Kitchen went to 9/5						Styrofoam Insul. in Crawl covered w/1" foil faced F.G.					
	Water in side of w/Htr.											
	Final plumbing test											
on final electrical												

RESIDENTIAL PLAN CORRECTION SHEET

CITY OF NAPOLEON
255 West Riverview Ave.
Napoleon, Ohio 43545
419/592-4010

ADDENDUM TO Permit No. 1139
Owner RON ZACHRICH
Contractor RON ZACHRICH BLDG.
Location 70 JOLLETTE DRIVE

Please note the items checked below and incorporate them into your plans as indicated: PERMIT NOT YET ISSUED, CORRECT PLANS AND RE-SUBMIT. PERMIT ISSUED, INCORPORATE ITEMS DURING CONSTRUCTION.

GENERAL		Show size of members supporting porch roof.	
<input checked="" type="checkbox"/>	Provide approved smoke detector(s) as req'd.	<input type="checkbox"/>	Provide double top plate for all bearing partitions and exterior walls.
<input checked="" type="checkbox"/>	Provide 1/2" gypsum wallboard between dwelling and garage, on garage side.	<input type="checkbox"/>	Provide design data for prefab wood truss.
<input checked="" type="checkbox"/>	Provide min. 1 3/8" solid wood door from garage to dwelling. (or equal)	<input checked="" type="checkbox"/>	Ceiling joists undersized in <u>GARAGE (2x8's)</u> .
	Submit fully dimensioned plot plan.	<input type="checkbox"/>	Roof rafters undersized in _____.
	Provide min. of 1-3'0" x 6'8" exit door.	PLUMBING AND MECHANICAL	
<input checked="" type="checkbox"/>	Provide min. 22" x 30" attic access opening.	<input checked="" type="checkbox"/>	Terminate all exhaust systems to outside air.
<input checked="" type="checkbox"/>	Provide min. 18" x 24" crawl space access opening.	<input checked="" type="checkbox"/>	Insulate ducts in unheated areas.
<input checked="" type="checkbox"/>	Provide approved sheathing or flashing behind masonry veneer.	<input checked="" type="checkbox"/>	Provide backflow prevention device on all hose bibs.
	Provide min. 15# underlayment on roof.	<input checked="" type="checkbox"/>	Terminate pressure and temperature relief valve drain in an approved manner.
<input checked="" type="checkbox"/>	Provide adequate fireplace hearth.	<input checked="" type="checkbox"/>	Provide dishwasher drain with approved air gap device.
<input checked="" type="checkbox"/>	Install factory built fireplaces/stoves according to manufacturers instructions.	METAL VENEERS	
<input checked="" type="checkbox"/>	Terminate chimney 2' above roof or 2' above highest point of building within 10' of chimney.	<input type="checkbox"/>	Contact City Utilities Dept. to remove conductors and/or meter.
LIGHT AND VENTILATION		<input type="checkbox"/>	Provide approved system of grounding and bonding.
<input checked="" type="checkbox"/>	Provide mechanical exhaust or window in bathroom <u>BOTH</u> .	ELECTRICAL	
<input checked="" type="checkbox"/>	Provide min. <u>875</u> Sq. In. net free area attic ventilation.	<input checked="" type="checkbox"/>	Show location of service entrance panel and service equipment panel.
<input checked="" type="checkbox"/>	Provide min. <u>133</u> Sq. In. net free area crawl space ventilation.	<input checked="" type="checkbox"/>	G. F. C. I. req'd. on temporary electric.
FOUNDATION		<input checked="" type="checkbox"/>	Outdoor, bathroom and garage receptacles shall be protected by G. F. C. I.
	Min. depth of foundation below finished grade is 32".	<input checked="" type="checkbox"/>	Maximum number of receptacles permitted on a G. F. C. I. circuit shall be 10 for 20 A. circuits and 7 for 15A. circuits.
	Min. size of footer _____ " x _____ "	<input checked="" type="checkbox"/>	Refrigerators, microwaves, washers, disposal, furnace and air conditioners shall be on separate circuits.
<input checked="" type="checkbox"/>	Provide anchor bolts, 1/2" @ 6' o.c. 1' from each corner. Embedded 7" in concrete and 15" in masonry.	INSPECTIONS	
	Show size of basement columns.	The following indicated inspections are required. The owner or his agent shall contact the City Building Dept. at least 24 hrs prior to the time the inspection is to be made.	
FRAMING		<input checked="" type="checkbox"/>	Footers and Setbacks
<input checked="" type="checkbox"/>	Show size of wood girder in <u>GARAGE DOOR</u> .	<input checked="" type="checkbox"/>	Building sewer.
	Provide design data for structural member in _____.	<input checked="" type="checkbox"/>	Foundation.
	Floor joists undersized in _____.	<input checked="" type="checkbox"/>	Plumbing rough-in.
	Provide double joists under parallel bearing partitions.	<input checked="" type="checkbox"/>	Plumbing final.
	Provide 1" x 4" let in corner bracing, approved sheathing, or equal.	<input checked="" type="checkbox"/>	Electrical service.
	Show size of headers for openings over 4' wide.	<input checked="" type="checkbox"/>	Electrical rough-in.
		<input checked="" type="checkbox"/>	Electrical final

Additional Corrections. STYROFOAM IN CRAWL MUST BE COVERED BY 3/8" PARTICLEBOARD OR EQUAL
PROVIDE LARGER WINDOW IN MASTER BEDROOM (MIN. 12.5 SQ. FT.), PROVIDE 3'x3' LANDINGS @ EACH SIDE OF EGRESS DOORS. CLOSET MUST BE MIN. 12" WIDER THAN FURNACE, SUPPLIED WITH COMBUSTION AIR AND SEPARATE FURNACE FROM CLOSET AREA.

The approval of plans and specifications does not permit the violation of any section of the Building Code or other City Ordinance. This addendum is attached to Permit No. 1139 and made a part thereof. DATE APPROVED OR DISAPPROVED 2-26-86 Checked by Ron Sonnenberg Plan Examiner.

DATE RECHECKED AND APPROVED _____ Checked by _____

100 run 7-28-76

Permit No 1137
Fee \$ 6.00

CITY OF NAPOLEON
BUILDING INSPECTION DEPARTMENT
APPLICATION FOR HEATING PERMIT
(PLEASE PRINT OR TYPE)

The undersigned hereby makes application for the installation, repla or alteration of a heating system or device as herein specified, agr to do all such work in strict accordance with the City of Napoleon's adopted Mechanical Code for 1, 2 and 3 Family Buildings.

Owner's Name Ron Zachrich Address Rt. 2 Napoleon
Contractor's Name Ron Zachrich Bldg Address 762-5277 Tel

BUILDING INFORMATION:

Single Family Double Family _____ Multiple New Construction
Addition _____ Remodel _____ Replacement _____ No. of Stories 1

DESCRIPTION OF WORK

Heating System - Warm Air Hot Water _____ Steam _____ Electric _____

Unit Heaters _____ Unit Gas Heaters _____ Other _____

Type - Gravity _____ Forced Radiant _____

No. of Thermostatical Heating Zone _____

Hot Water - One Pipe _____ Two Pipe _____ Series Loop _____

Electric Heat - No. of Circuits _____ Other _____

Total Heat Loss of Area to be Heated 110,000 Btu

Rated Capacity of Furnace/Boiler _____

No. of Furnaces 1 No. of Hot Air Runs 8

No. of Hot Water Radiators _____ Type of Fuel _____

Heating Units Located: Crawl Space _____ Floor Level Suspended _____

Roof or Exposed to Outside Air _____ Attic _____ Other _____

APPLICATION FOR PERMIT SHALL BE ACCOMPANIED BY TWO COMPLETE SETS OF P INCLUDING: LOCATION OF FURNACE OR UNIT HEATERS AND SIZE AND LOCATION FEEDER DUCTS AND RETURN AIR DUCTS. ALL PLANS SHALL BE DRAWN TO SCALE

ESTIMATED COST OF COMPLETED PROJECT: Included in General

DATE 2-20-86 APPLICANT'S SIGNATURE Ron Zachrich
OWNER-CONTRACTOR-AGEN

CITY OF NAPOLEON
BUILDING INSPECTION DEPARTMENT
APPLICATION FOR BUILDING PERMIT
(Please print or type)

The undersigned hereby makes application for construction, installation, or alteration work as herein specified, agreeing to do all such work in strict accordance with the City of Napoleon's adopted Building Codes.

Location of project Lot 74 Jolet Cost of project 52,000⁰⁰
Owner's Name Ron Zachrich Address _____
Contractor Ron Zachrich Bldg Telephone No. 762-5277
Address Rt. 2 Napoleon

Lot Information: (Not required for siding job)
Lot No. 74 Subdivision Riviera
Zoning District _____ Lot Size 78.99 ft. x 125 ft. Area 9873 sq. ft.
Setbacks: Front 25' Right Side 7'6" Left Side 7'6" Rear 55'

Work Information:
Residential Commercial _____ Industrial _____
New Construction Addition _____ Remodel _____
Accessory Building _____ Siding _____ (Specific Type)

Brief Description of Work:-----

Size: Length 64' Width 34'4" No. of Stories 1
Area: 1st Floor 1384 sq. ft. Basement _____ sq. ft.
2nd Floor _____ sq. ft. Accessory Bldg. _____ sq. ft.
3rd Floor _____ sq. ft. Other Garage 440 sq. ft.

Additional Information: _____

APPLICATION FOR PERMIT SHALL BE ACCOMPANIED BY TWO COMPLETE SETS OF PLANS INCLUDING: ELEVATIONS, FLOOR PLANS, CROSS SECTIONS AND PLOT PLAN. IF ADDITION OR REMODELING, SHOW ALL EXISTING STRUCTURES AND THEIR SIZE AND LOCATION. ALL PLANS SHALL BE DRAWN TO SCALE.

Date 2-20-86 Applicant's Signature Ron Zachrich

PERMIT NO. 1139
PERMIT FEE \$ 87.00

PLOT PLAN

9855-1-10-01

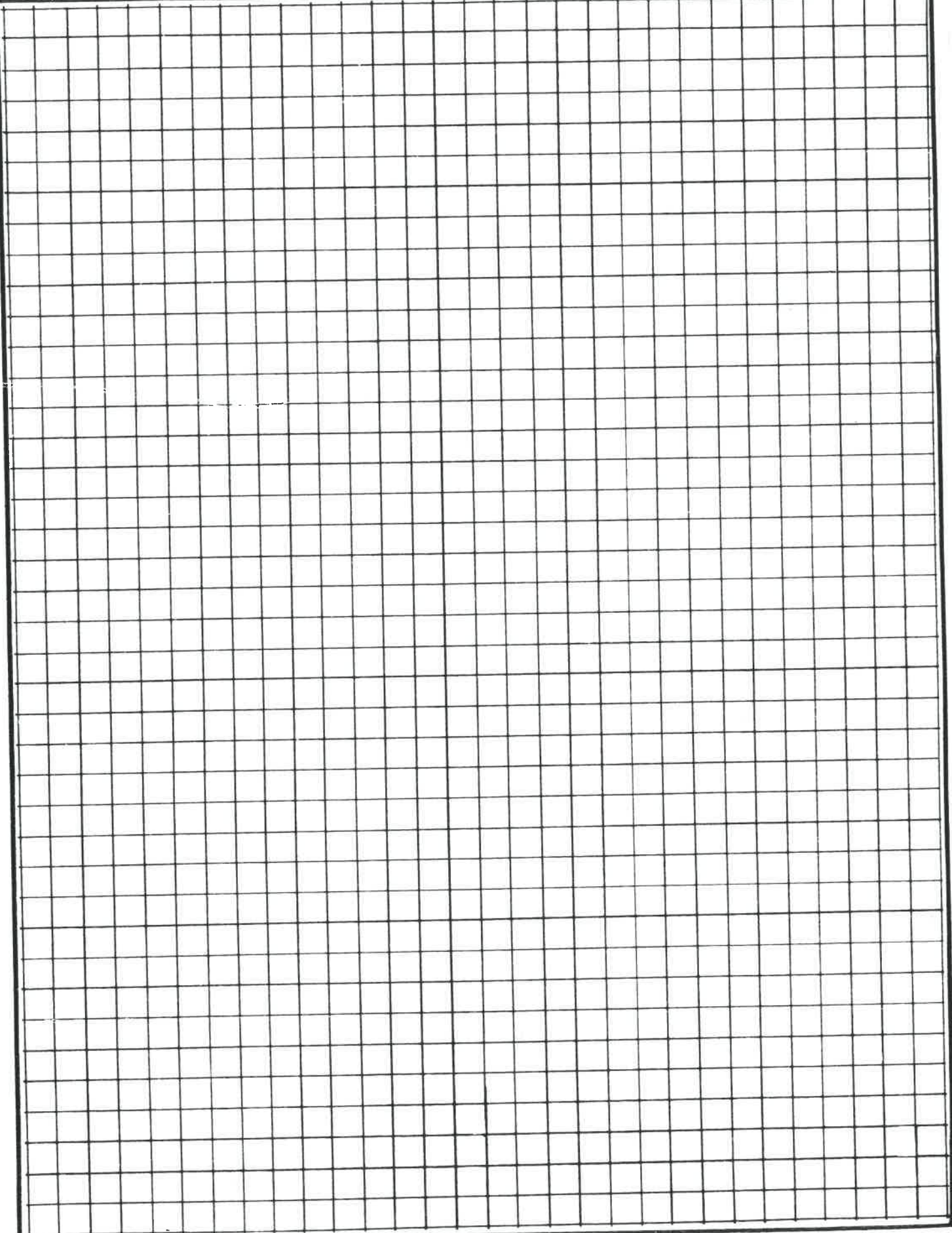

CITY OF NAPOLEON
BUILDING INSPECTION DEPARTMENT
APPLICATION FOR ELECTRICAL PERMIT
(Please print or type)

The undersigned hereby makes application for installation or replacement of electrical equipment as herein specified, agreeing to do all such work in strict accordance with the City of Napoleon's adopted Electrical Codes.

Owner's Name Ron Zachrich Address Rt. 2 Napoleon

Electrical Contractor Ron Zachrich Bldg Telephone No. 762-5277

Address Rt. 2 Napoleon 0

General Contractor Stone Telephone No. "

Address _____

Location of Project Joliet Dr Cost of Project Incl in Gen

Work Information:

Residential Commercial _____ Industrial _____

No. Units _____
New Service Change _____ Rewiring _____ Additional Wiring _____

Brief Description of Work: _____

Size of proposed service entrance 200 Number of new circuits 18

Type of proposed service entrance Underground _____ Overhead _____

Require Temporary Electric yes (Yes or No)

Total Floor Area - Commercial and Industrial only _____ sq. ft

Additional Information: _____

*Ground fault circuit interrupter protection is required on all 120-volt single phase, 15 and 20 amp. Circuits which are part of a temporary electric service: and also on bathroom, outdoor, and garage receptacles in all dwelling units. Art. 210-8 N.E.C.

*Application for permit shall be accompanied by two complete sets of plans including: Electrical layout and riser diagram. (For commercial and industrial work only).

Date 2-20-86 Applicant's Signature Ron Zachrich

PERMIT NO. 1139
PERMIT FEE \$ 23.00
Temp. Elect \$ 10.00

CITY OF NAPOLEON
 BUILDING INSPECTION DEPARTMENT
 APPLICATION FOR PLUMBING PERMIT
 (Please print or type)

The undersigned hereby makes application for the installation or replacement of plumbing as herein specified, agreeing to do all such work in strict accordance with the City of Napoleon's adopted Plumbing Codes. (1, 2 and 3 family dwelling units only).

Owner's Name Ron Zachrich Address Rt. 2 Napoleon
 Plumbing Contractor Meyers Htg Plbg Telephone No. _____
 Address N. Perry St, Napoleon
 General Contractor Ron Zachrich Bldr Telephone No. 762 5277
 Address Rt. 2 Napoleon
 Location of Project Joliet Drive Cost of Project Inch. in Ga

Work Information:

No. of dwelling units 1 New Replacement _____ Addition _____
 Brief description of work: _____

Is water tap required Size 3/4 Type of Pipe plastic
 Is sewer tap required Size 4" Type of Pipe plastic
 Type of Water Distribution pipe DVC
 Type of Drainage, Waste and Vent Pipe DVC
 Size of main building drain 4" Size of main vent pipe 3"
 Water closets 2 Bathtubs 1 Shower 1
 No. Trap Size No. Trap Size
 Lavatories 2 1 1/2 Kitchen Sink 1 1 1/2 Disposal 1 1 1/2
 No. Trap Size No. Trap Size No. Trap Size
 Dishwasher 1 1 1/2 Clothes Washer 1 1 1/2 Other _____
 No. Trap Size No. Trap Size No. Trap Size

PERMIT NO. 1139
 PERMIT FEE \$ 1300

Water Tap \$300.00
 Sewer Tap \$60.00

All installations are subject to plumbing tests and/or inspections.
 Date 2-20-86 Applicant's Signature Ron Zachrich

APPLICATION FOR PERMIT TO TAP SEWER

Owner Ron Zachrich
ADDRESS Rt. 2 Napoleon, Ohio 43545
CONTRACTOR Same
ADDRESS Same TEL. 762-5277

NO. _____
BLDG. PERMIT 1139
PERMIT FEE \$ 60.00
STREET BOND n/a
DATE PAID March 10, 1986
For office use only

LOCATION OF CONNECTION

Street and No. 70 Jolliette Sanitary XXX Storm _____
Lot No. 74 Subdivision Riviera Heights Size of Tap 4"
Size and Type of Sewer 4" PVC ALL WORK MUST BE INSPECTED
Street to be opened-Yes _____ No XX Opening bond fee set by Engineer \$ _____
Street opening agreement approval date _____

I certify that the sewer will be used only as indicated and no other drainage will be connected.

Date _____ Signature _____
Owner-Builder-Agent

DO NOT WRITE BELOW THIS LINE

INSPECTION RECORD

Date Inspected April 1986 Size and Type of Sewer 4" PVC
Location 70 Jolliette Dr. Depth 2' to 7' Type of Test NONE
Inspected and Approved by: Ron Sonnenberg April 1986
Inspector Date

Additional information _____

Send copy to: _____

SKETCH OF INSTALLATION - ON BACK

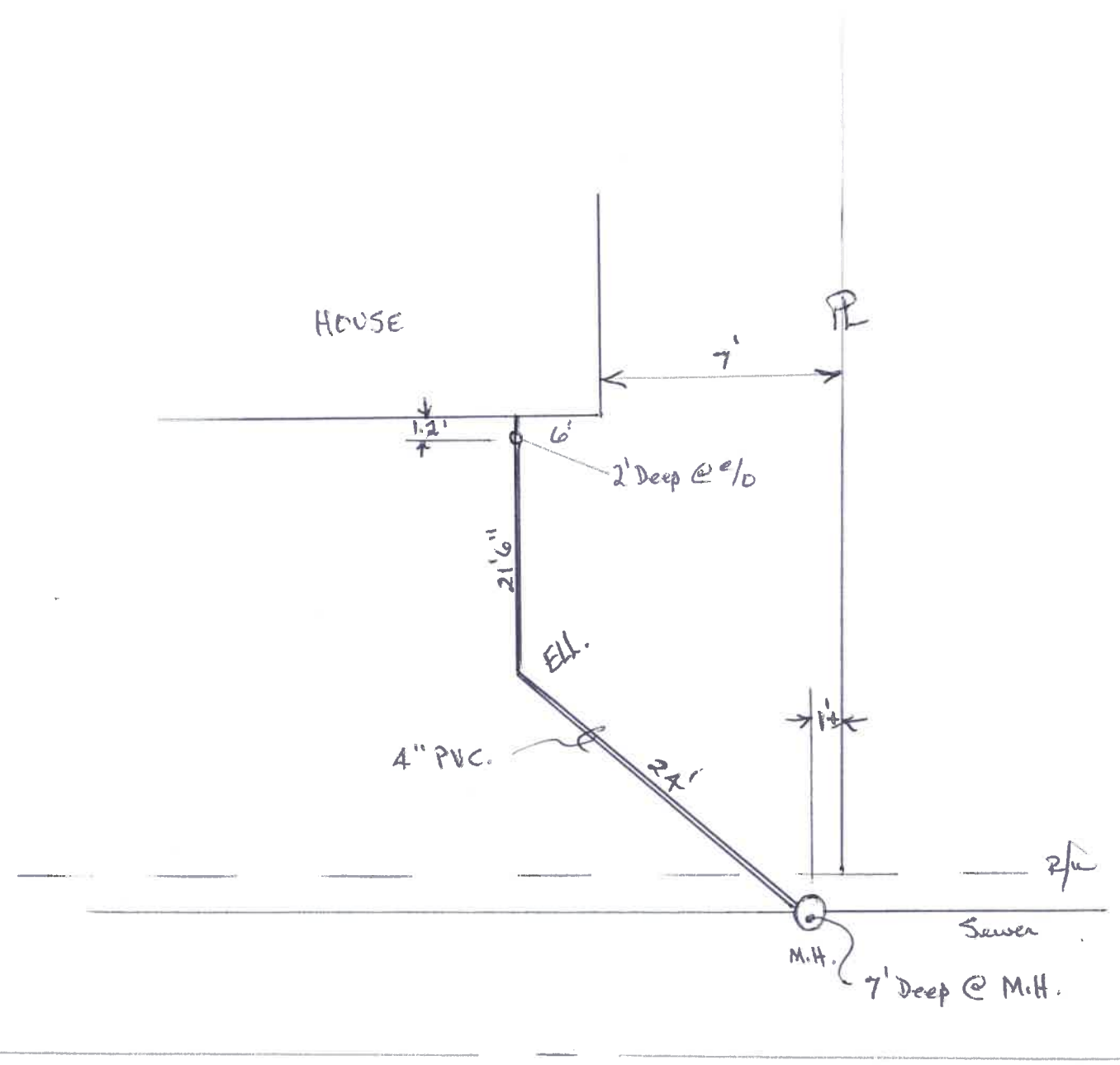

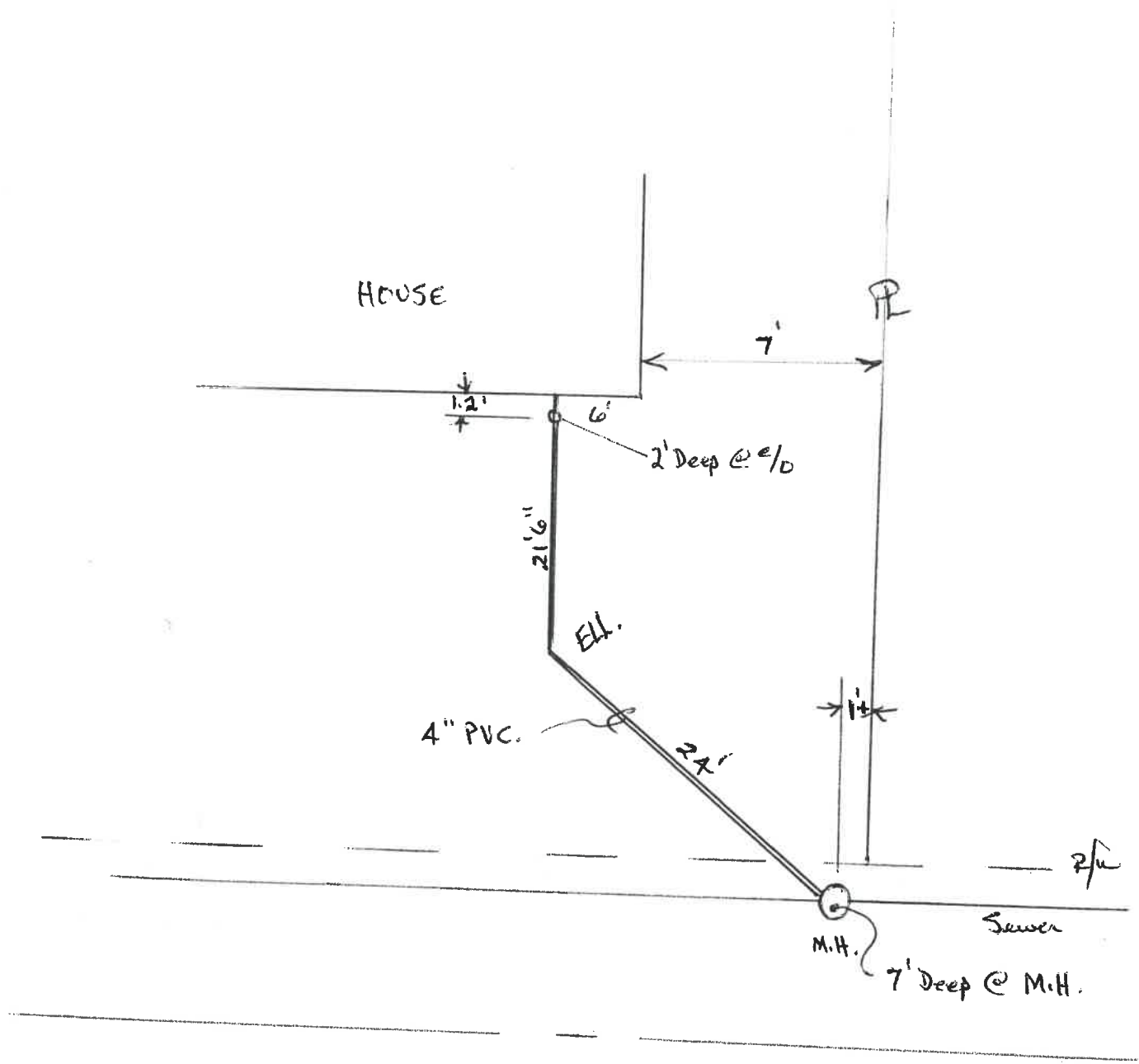

CERTIFICATE OF OCCUPANCY
THE CITY OF NAPOLEON

ENGINEERING DEPARTMENT
DIVISION OF INSPECTION

No. 428.....

This is to certify that the Building or Land as herein described complies with all the building and health laws and ordinances and with the provisions of the Zoning Ordinance.

Location of Occupancy 70 Joliette Drive Occupancy Single family residence
Owner of Property Ron Zachrich Address Route 2, Napoleon, Ohio
Issued to Ron Zachrich Address Route 2, Napoleon, Ohio
Zoning "A" Residence Bldg. Permit No. 1139

Substantial qualifications of occupancy

This certificate is issued by the City Building Inspector, as provided by law, and is to certify that construction is completed substantially in conformity with the approved plans and permission is hereby granted to occupy such building in compliance with such legal use and occupancy as authorized under the provisions of the ordinances of the City of Napoleon.

Issued this 23rd day of June 1986

This is a valuable record for owner or lessee and should be so preserved.

Signed *Ronald D. Lawrence*
City Building Inspector

PERMIT

CITY OF NAPOLEON - BUILDING DEPARTMENT
 255 West Riverview Avenue, Napoleon, Ohio 43545 - 419-592-4010

Permit No. 01139 Issued 2-26-86
date

Job Location 70 Joliette Drive
address

Lot 74 Riviera Heights 3rd. Add'n.
sub-div or legal discript

Issued By Ron Zachrich
building official

Owner Ron Zachrich 762-5277
name tel.

Address Route 2 Napoleon, Ohio 43545

Agent Ron Zachrich Bldr. 762-5277
builder-eng.-etc. tel.

Address Rt. 2 Napoleon, Ohio 43545

Description of Use Residential

Residential one
no. dwelling units

Commercial _____ Industrial _____

New XX Add'n. _____ Alter _____ Remodel _____

Mixed Occupancy n/a

Change of Occupancy n/a

Estimated Cost \$ 52,000.00

FEES	BASE	PLUS	TOTAL
BUILDING	\$87.00	-0-	\$ 87.00
ELECTRICAL	5.00	\$18.00	23.00
PLUMBING	3.00	10.00	13.00
MECHANICAL	6.00	-0-	6.00
DEMOLITION			
ZONING	-0-	-0-	-0-
SIGN			
WATER TAP	300.000	-0-	300.00
SEWER TAP	60.00	-0-	60.00
TEMP. ELECT.	10.00	-0-	10.00
ADDITIONAL PLAN REVIEW	Struct. _____ hrs	Elect. _____ hrs	
TOTAL FEES.....			\$499.00
LESS MIN. FEES PAID _____ <small>date</small>			-0-
BALANCE DUE.....			\$499.00

ZONING INFORMATION

district <u>A</u>	lot dimensions <u>78.99' x 120'</u>	area <u>9873 sq. ft.</u>	front yd <u>25'</u>	side yds <u>7' min.</u>	rear yd <u>15' min</u>
max hgt <u>35'</u>	no pkg spaces <u>two</u>	no ldg spaces <u>n/a</u>	max cover <u>35%</u>	petition or appeal req'd <u>no</u>	date appr <u>n/a</u>

WORK INFORMATION:

Size: Length 64' Width 34'4" Stories 1 Ground Floor Area 1824 sq. ft.
 Height 1 story Building Volume (for demo. permit) _____ cu. ft.

Electrical: New 200 A. Service and 18 circuits.
brief description

Plumbing: Water & san. Sewer service & interior plumbing.
brief description

Mechanical: 110,000 BTU warm air furnace.
brief description

Sign: n/a Dimensions _____ Sign Area _____
type

Additional Information: See attached Addendum.

Date 3-10-86 Applicant Signature Ron Zachrich
owner-agent

PAID

MAR 10 1986

CITY OF NAPOLEON

FINAL FLOODING
6-24-86 FH

70 SOCIETY-DRIVE

ALL SINKS HAVE VALVES

WATER COLUMN TEST O.K.

