

OK

# THE CITY OF NAPOLEON

BUILDING & ZONING DEPARTMENT

255 W. RIVERVIEW

(419)592-4010

**Building Permit**

Permit Number: BP2007-105

Page 1 of 1

Printed: 6/26/2007

**ADDRESS:**

**1121 Willard St.**

**Applicant**

**Name:** Richard Cordes  
**Address:** 1121 Willard St

**Approval Date:** 6/26/2007  
419-592-8330

**Owners**

**Name:** Mr. Richard Cordes  
**Address:** 1121 Willard St  
Napoleon, OH 43545

**Phone:** 419-592-8330

**Contractors**

**Contractor Type:** GENERAL CONTRACTOR

**Name:** C & C Home Repair  
**Address:** 1046 N Perry St

Napoleon, OH 43545

**Phone:** 419-599-1391

**Fees and Receipts:**

Number	Description	Amount
FEE2007-351	Building Permit Fee (Auto)	\$22.00
FEE2007-352	State 1% fee (Calc)	\$0.22
<b>Total Fees:</b>		<b>\$22.22</b>
RCPT2007-302		\$22.22
<b>Total Receipts:</b>		<b>\$22.22</b>

garage addition. BZA 07-02

APPLICANTS SIGNATURE: \_\_\_\_\_

REMINDER: YOU MUST CALL (419)592-4010 FOR AN INSPECTION



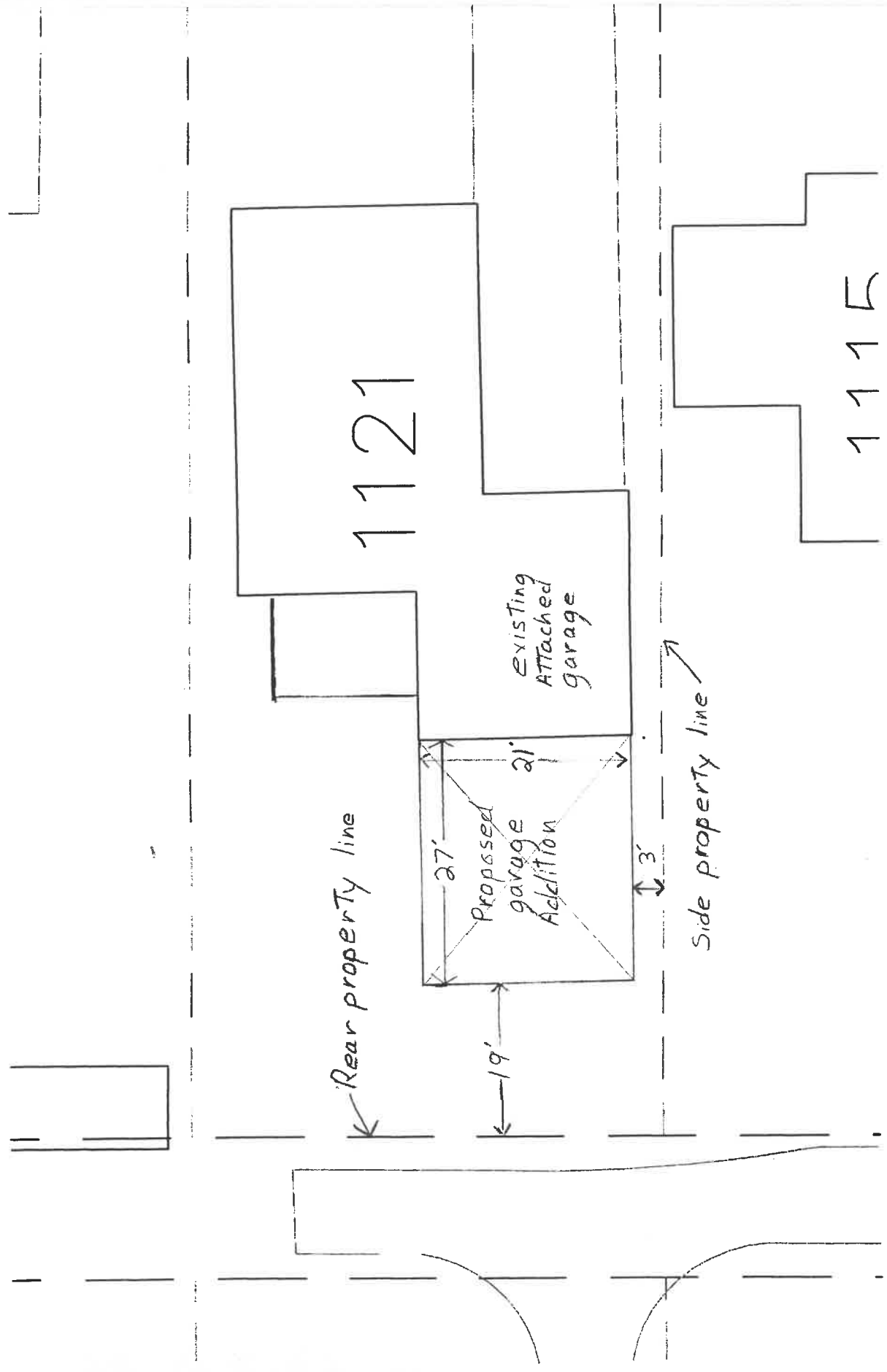

Rear property line

1121

Proposed garage Addition

19'

27'

21'

Existing Attached Garage

3'

Side property line

1115

BPO7-105

# CITY OF NAPOLEON GENERAL PERMIT APPLICATION

THIS APPLICATION IS FOR RESIDENTIAL CONSTRUCTION INCLUDING BUILDING, ELECTRICAL, PLUMBING, MECHANICAL, DEMOLITIONS, REMODELING.

DATE: 6-26-07 JOB LOCATION: 1127 Wilena St

OWNER: Rick Case PHONE: 594-8330

OWNER ADDRESS: 1127 Wilena St CITY: Ohio ZIP: 43545

CONTRACTOR: CC Home Repair

PHONE #: \_\_\_\_\_ CELL PHONE# \_\_\_\_\_

CONTRACTOR LICENSED WITH THE CITY OF NAPOLEON?: YES  NO:

Is any of the above job going to be subcontracted out? Yes  No:

If yes to whom: \_\_\_\_\_

DESCRIPTION OF WORK TO BE PERFORMED: garage addition  
ESTIMATED COMPLETION DATE: \_\_\_\_\_

### PLEASE MARK THE TYPE OF WORK YOU WILL BE PERFORMING

- |   |   |
|---|---|
| <input checked="" type="checkbox"/> A/C ADD ON 1%             | <input type="checkbox"/> REMODELING 1%                |
| <input type="checkbox"/> BOILER REPLACEMENT 1%                | <input type="checkbox"/> ROOFING 1%                   |
| <input type="checkbox"/> CURBING                              | <input type="checkbox"/> SEWER REPAIRS**              |
| <input type="checkbox"/> DECKS * 1%                           | <input type="checkbox"/> SIDEWALK*                    |
| <input type="checkbox"/> DRIVEWAY*                            | <input checked="" type="checkbox"/> SIDING 1%         |
| <input type="checkbox"/> ELECTRICAL SERVICE UPGRADE 1%        | <input type="checkbox"/> SHED* (under 200 sq ft)      |
| <input checked="" type="checkbox"/> ELECTRICAL SERVICE NEW 1% | <input type="checkbox"/> SHED* (over 200 sqft) 1%     |
| <input type="checkbox"/> SWIMMING POOL* 1%                    | <input type="checkbox"/> FENCE*                       |
| <input type="checkbox"/> FURNACE REPLACEMENT 1%               | <input type="checkbox"/> TEMP ELECTRIC 1%             |
| <input type="checkbox"/> ADDITIONS* 1%                        | <input type="checkbox"/> FURNACE NEW 1%               |
| <input type="checkbox"/> WATER TAP (size _____")              | <input checked="" type="checkbox"/> WINDOWS /DOORS 1% |
| <input type="checkbox"/> LAWN METER 1%                        |   |
| <input type="checkbox"/> PLUMBING 1%                          |   |

### 1%- EFFECTIVE JUNE 1, 2007 BOARD OF BUILDING STANDARDS FEE

\*PLEASE INCLUDE A PICTURE SHOWING MEASUREMENTS FROM EXISTING STRUCTURES AND PROPERTY LINES. INDICATING THE TYPE OF WORK YOU WISH TO PERFORM.

\*\* IF WORK REQUIRES GOING INTO THE STREET A STREET BOND IS REQUIRED!

FOR PERMIT COSTS PLEASE FILL OUT REVERSE SIDE.

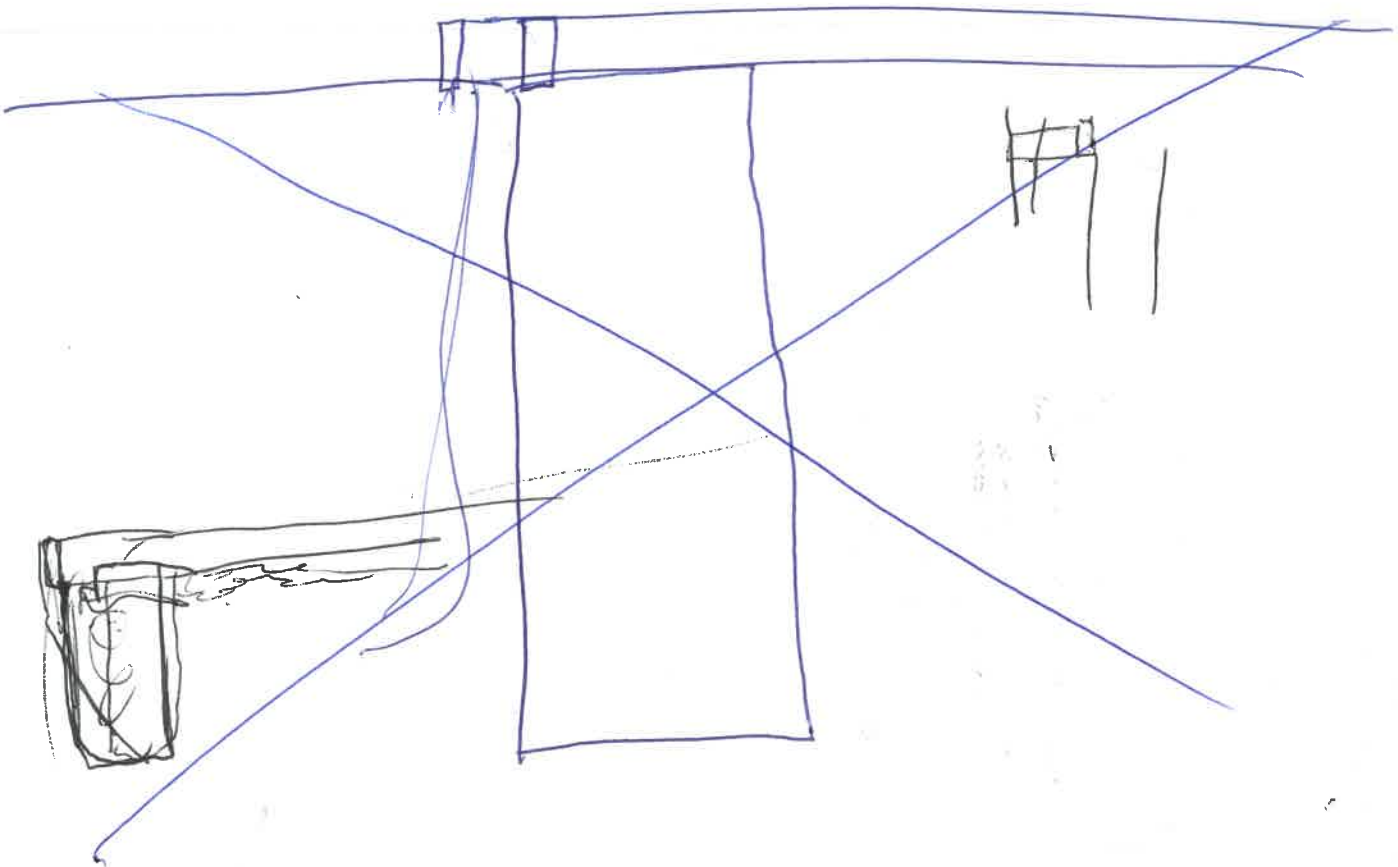
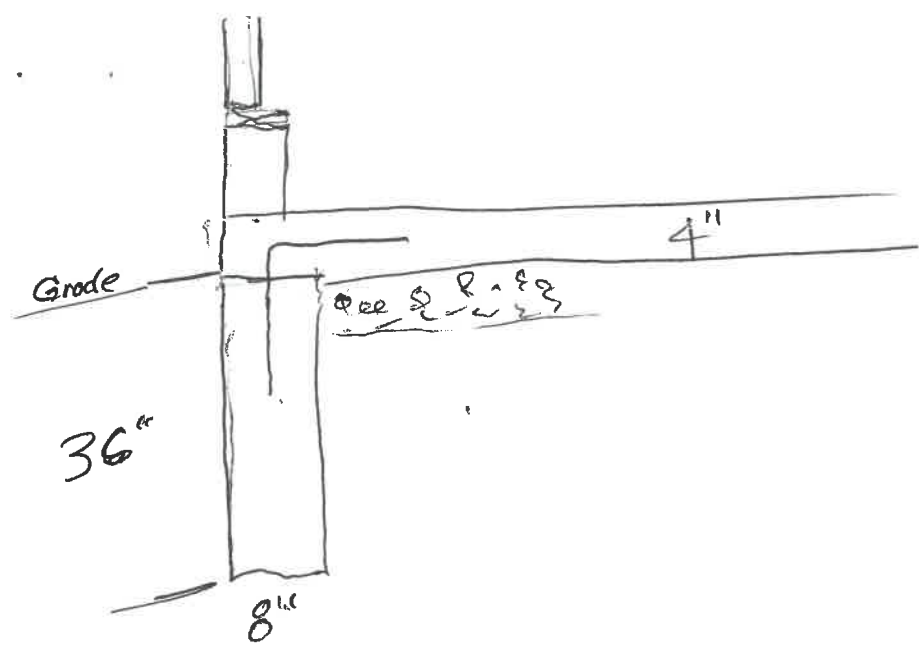

F

**THE CITY OF NAPOLEON**  
**BUILDING & ZONING DEPARTMENT**  
**255 W. RIVERVIEW**  
**(419)592-4010**



---

**Inspections**

Page 1 of 1

**Address:** 1121 Willard St.  
Napoleon, OH 43545

Printed: 10/11/2007

**Applicant:** Richard Cordes

**Permit Number:** BP2007-105

---

<b>Inspection Date:</b> 9/14/2007	<b>Inspector:</b> Tom
<b>Inspection Number:</b> INSP2007-253	<b>Status:</b> Approved
<b>Inspection Type:</b> Framing	<b>Passed?</b> <input checked="" type="checkbox"/>

**Required Steps:**

**Comments:**

---

<b>Inspection Date:</b> 10/11/2007	<b>Inspector:</b> Tom
<b>Inspection Number:</b> INSP2007-270	<b>Status:</b> Complete
<b>Inspection Type:</b> Building Final	<b>Passed?</b> <input checked="" type="checkbox"/>

**Required Steps:**

**Comments:** oked 1 hour fire-resistive construction under overhang

---

**Other Fields:**

5 22332 02317 0

Fire Resistive Gypsum Exterior Ceiling / Soffit Board — Type X For Fire Safety Information, See [www.nationalgypsum.com](http://www.nationalgypsum.com)

SB 01-03

**GOLD BOND<sup>®</sup> BRAND GOLD BOND<sup>®</sup> BRAND FIRE-SHIELD<sup>®</sup> SOFFIT BOARD**

*used under overhang*